The background image shows a road construction site. In the foreground, a large area of dark asphalt has been laid. Several workers in high-visibility vests are visible, some standing near a yellow paving machine and others further down the road. A red concrete mixer truck is parked on the left. In the background, there are residential houses and bare trees under a clear blue sky.

# **Village of Plainfield Old Town Neighborhood Improvements Phase 1 and Phase 2**

**Project Informational Meeting  
Wednesday, January 25, 2023, 5:00 pm  
Public Works Facility**

# Meeting Goals

- Update on Construction of Phase 1 (Lockport St and Eastern Ave)
- Review in-progress Design for Phase 2 for Underground Utilities (Center St, Bartlett Ave, Amboy Ave, Evans St)
- Review in-progress Design for Phase 2 for Roadway and Sidewalks (Center St, Bartlett Ave, Amboy Ave, Evans St)
- Discuss Project Concerns

# Project Location and Phasing

2022/2023 Utility Construction  
Lockport Street & Eastern Avenue

2023 Utility Construction  
Amboy Street, Bartlett Avenue,  
Center Street, Evans Street

2024 Roadway Reconstruction  
Lockport Street, Eastern Avenue,  
Amboy Street, Bartlett Avenue,  
Center Street and Evans Street

New Pedestrian Crossings at  
Railroads  
*Local Federal Rail Safety Program  
Funding Secured*

2025 - 2027 Construction  
South of Lockport Street

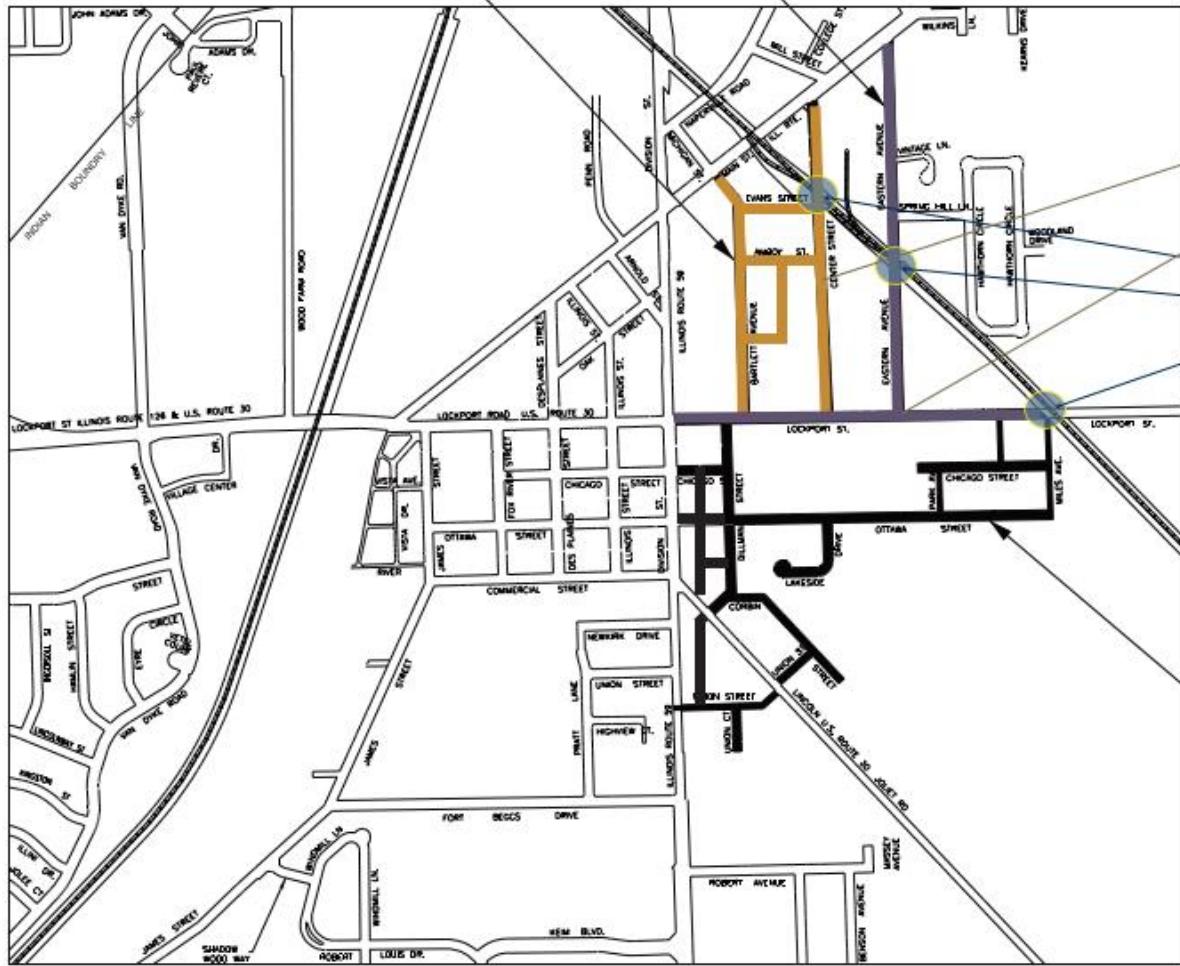

# Phase 1 Construction Update

---

- **Completed in 2022 (late August – late November)**
  - Installed approx. 2,200 feet of new watermain
  - Installed approx. 35 water services (including full lead line replacement)
  - Miscellaneous stormwater work
  - Sanitary manholes replacement
  - Temporary asphalt patching



# Phase 1 Construction Update

- **Remaining Work Lockport Street:**
  - Watermain Railroad crossing (anticipated start March/April 2023)
  - Water service replacement (south side, west of Center St)
  - Storm Sewer Work
- **Remining Work Eastern Avenue:**
  - Watermain (including Railroad crossing)
  - Water services
  - Storm Sewer
- **To be completed by July 2023**



# Phase 2 Utility Design Update

- **Scope of Work:**
  - **Center Street**
    - New Watermain and services (including railroad crossing)
    - New storm sewer
  - **Bartlett Avenue**
    - New Watermain and services
    - Storm sewer improvements
  - **Amboy Street and Evans Street**
    - New Watermain and services
    - New storm sewer

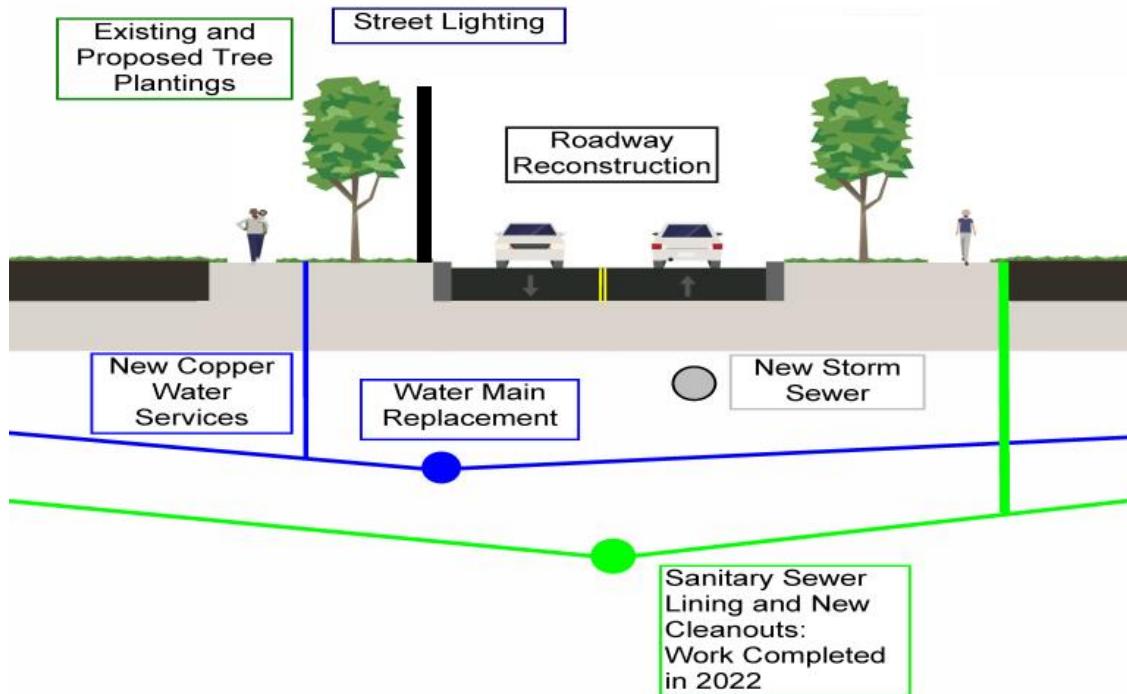

# Phase 2 Utility Design Update

- Anticipated Project Schedule

- Prefinal Plans completed last week
- Final Plans at the end of February
- Bid construction contract on March 1<sup>st</sup>
- Bid Opening on April 5<sup>th</sup>
- Bid Award (Includes IEPA Review and Approval) on June 20<sup>th</sup> or July 3<sup>rd</sup>
- Start Construction in July 2023
- Final Completion in spring of 2024.

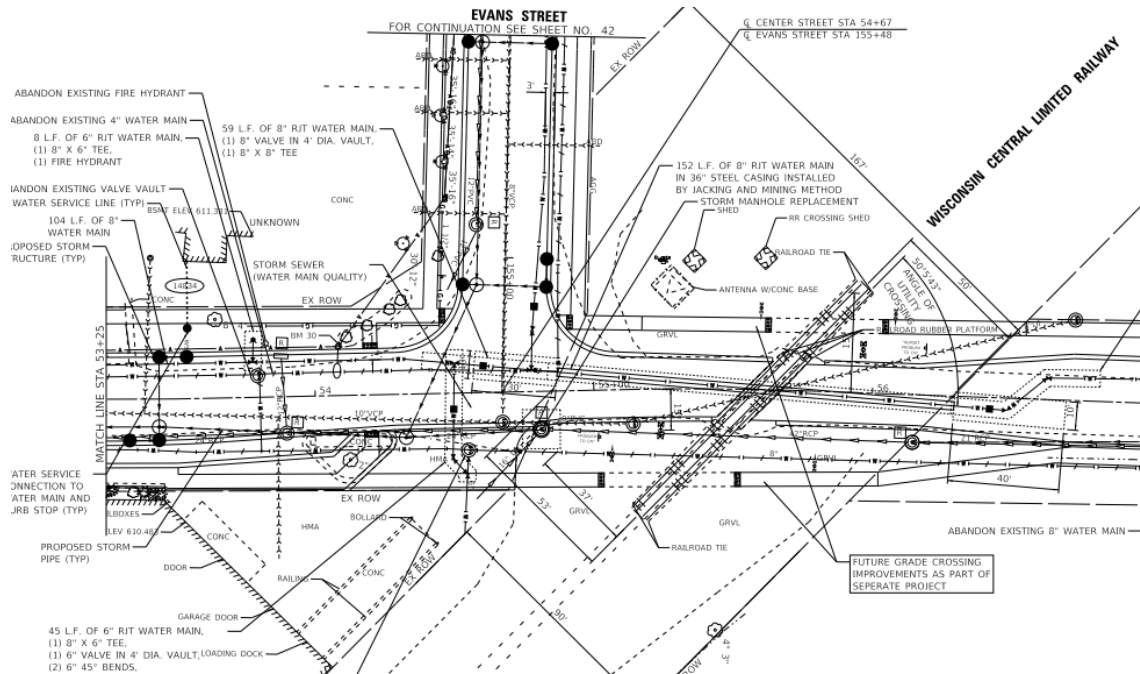

# Water Main Improvements

- Water Mains
  - Wholesale Replacement of ~100-Year-Old Cast Iron Mains
  - Installation of New Valves and Fire Hydrants
    - Increase Fire Flow and Redundancy
- Water Services
  - Replacement of Village Portion of Water Services From Main to B-Box
  - Replacement of Property Owner Portion of Lead Water Services (at Village Cost)



# Storm Sewer Improvements

- Storm Sewer Mains
  - Installation of New Mains, Manholes, Inlets and Catch Basins
- Storm Sewer Services
  - Installation of Select Storm Sewer Services

# Utility Adjustments

- Utility Adjustments
  - Select ComEd pole relocation
  - Potential gas main and/or services replacement prior to roadway work



# Phase 2 Roadway Design Update

- **Scope of Work:**

- Reconstruct/Resurface Pavement
- Replace/add Curb and Gutters
- New Sidewalks on Both Sides
  - Railroad Pedestrian Crossings
- Traffic Calming Measures
- Replace all Driveway Aprons with Concrete
- Add Decorative Streetlight
- Root prune/tree preservation
  - Planting of New Trees
- Lawn Restoration With Sod

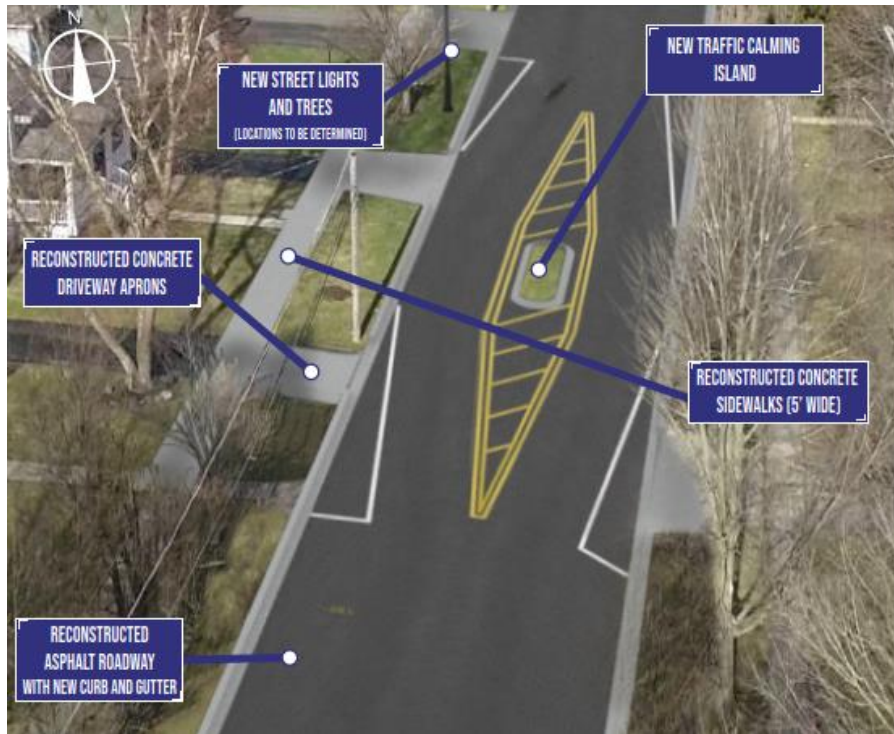

# Phase 2 Roadway Design Update

- Anticipated Project Schedule
  - Construction to include Lockport St, Eastern Ave, Center St, Bartlett Ave, Amboy St and Evans Ave
  - To be completed in 2024

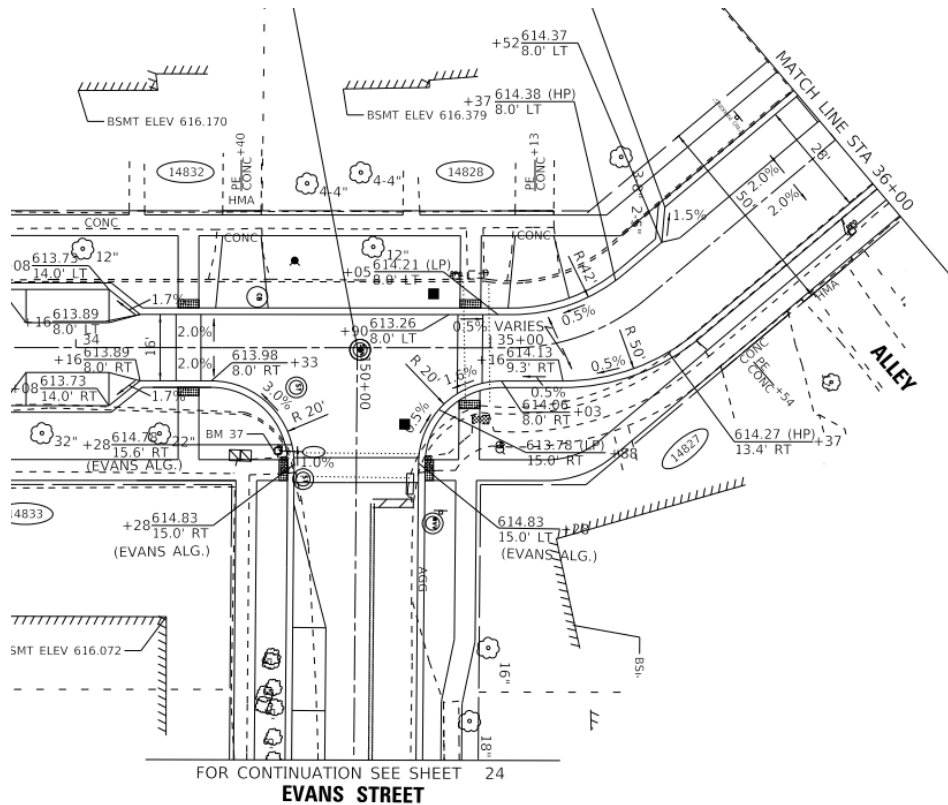

# End of Presentation

- Questions?
- Opportunity to review plans, ask further questions, and provide feedback to engineers